

REDLINE PARLUX

**TRIPLE TAILGATE LIGHT BAR (2PC)
FOR 2005~2023 TACOMA GEN 2/3**

INSTALLATION GUIDE

WHAT'S INCLUDED

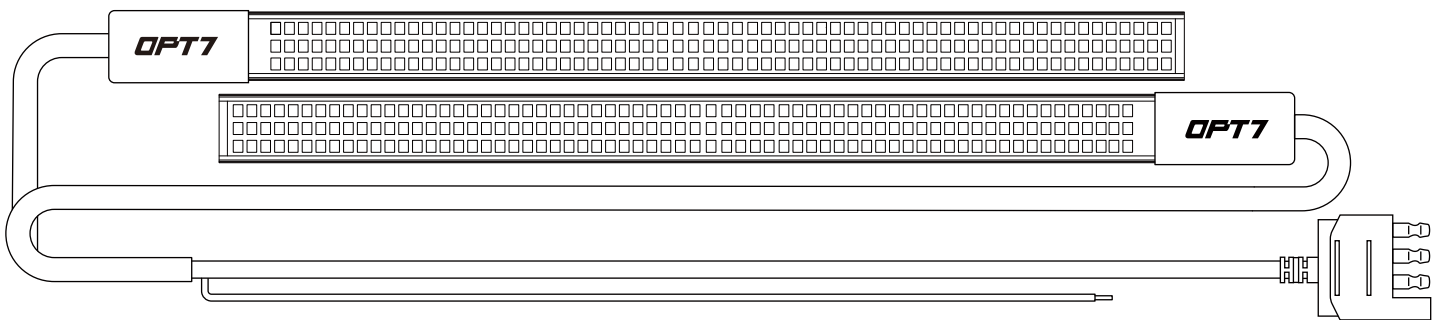

1X Triple Redline LED Bar



1X Plastic Aligner (*Use this part for Option 1, Step 4-5)



1X EVA foam (*Use this part for Option 1, Step 4-5)

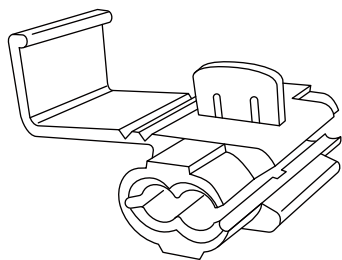

2X Scotch-Lok
Wiring Connectors

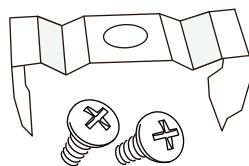

4X Mounting
Clips



1X Adhesive
Promoter

INSTALLATION

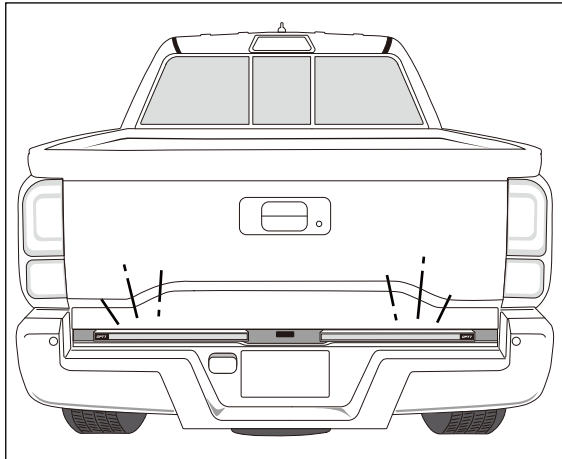

STEP 1

Before mounting the Redline Light Bar, perform a bench test by connecting the Redline LED Light Bar to the vehicle. Ensure all the lighting functions work.

*RECOMMENDATION: For a successful install, we encourage you to carefully remove the truck's tailgate from the vehicle to achieve the best results.

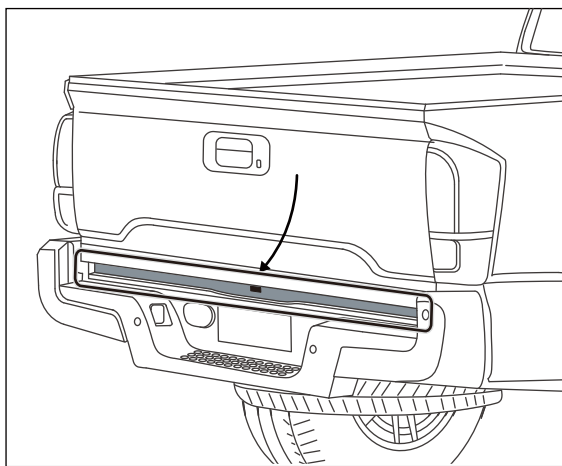

STEP 2

Once you have removed the tailgate, prep the area by taking a wash cloth to remove any dirt and debris from the area. Next, using the Adhesive Promoter apply in the area you will be mounting the light bar.

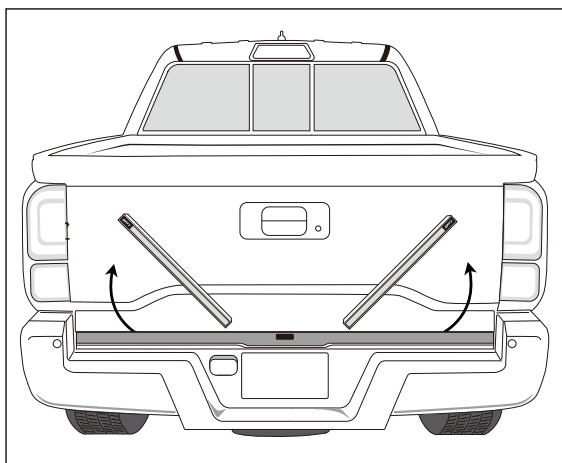

STEP 3

Position the Redline Light Bar according to your preference, with the center hatch as a reference point for measurement. For accurate sequential alignment of the light bar, ensure that the OPT7 logos on each end of the vehicle are oriented correctly.

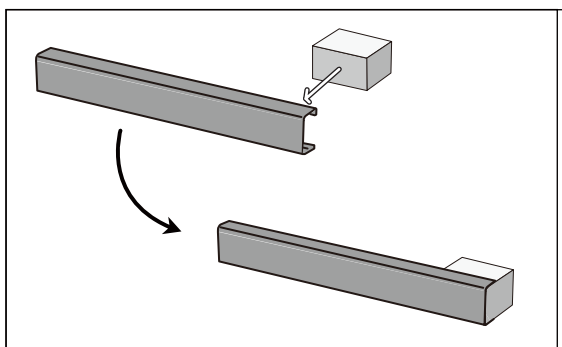

STEP 4

Utilize the EVA and Plastic Aligner to achieve a parallel and horizontal alignment of the LED bars. The EVA will need to be temporarily inserted into the middle gap hitch.

OPTION 1

INSTALLATION

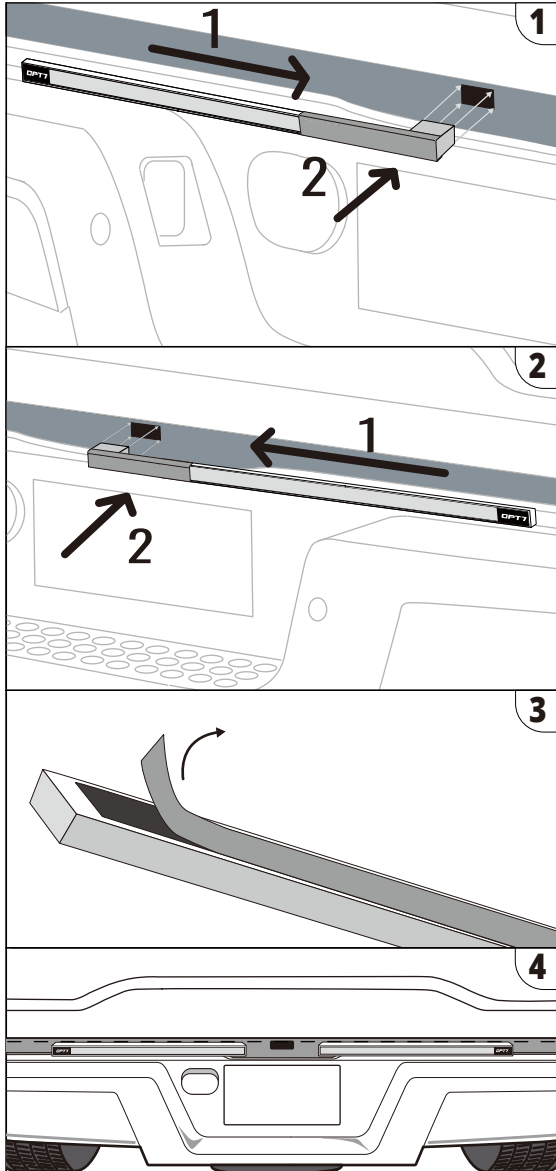

STEP 5

- 1 Take the Plastic Aligner and connect to the LED bar to level the light bar for the left side of the vehicle.
- 2 Next, repeat this step for the right side of the vehicle.
- 3 Gently remove the adhesive backing from each LED light bar.
- 4 Ensure both LED light bars are mounted at the same level.

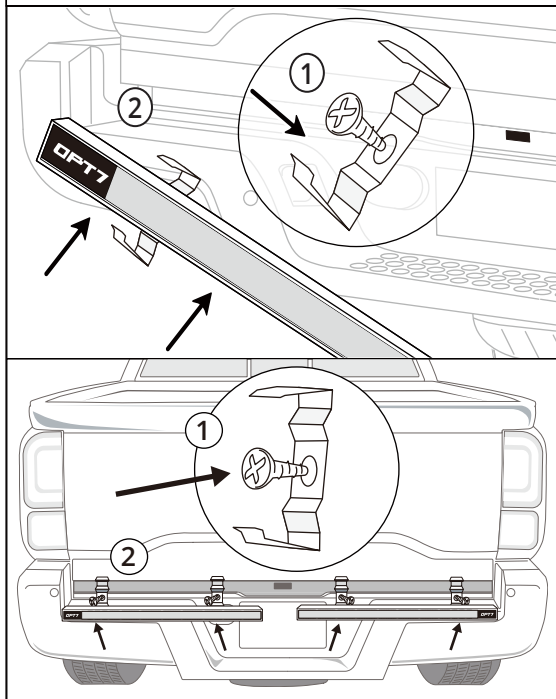

STEP 4

For optimal installation of the Redline LED Bar, carefully plan and mark the desired bracket mounting locations, taking placement into consideration to ensure a straight application.

OPTION 2

STEP 5

Securely mount the Redline LED Bar to your vehicle using the provided screws and clips to ensure a solid installation.

INSTALLATION

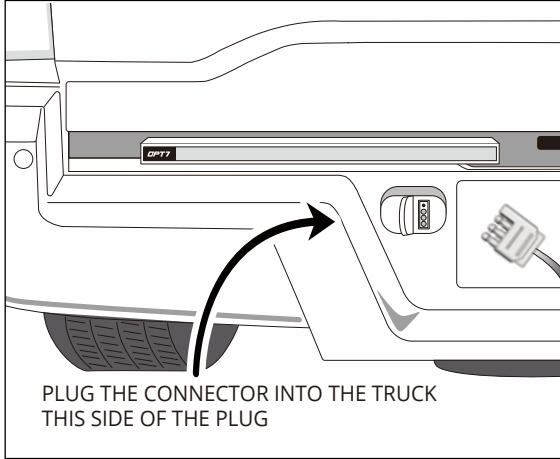

STEP 6

OPTION 1: You may plug the 4-pin flat connector into the proper receptacle on the vehicle.

OPTION 2: For a neater installation while retaining the ability to use your trailer plug, consider utilizing the OPT7 Redline Dual 7-Pin Splitter to 4 Foot 4-Pin Extension Adapter Harness available on our website.

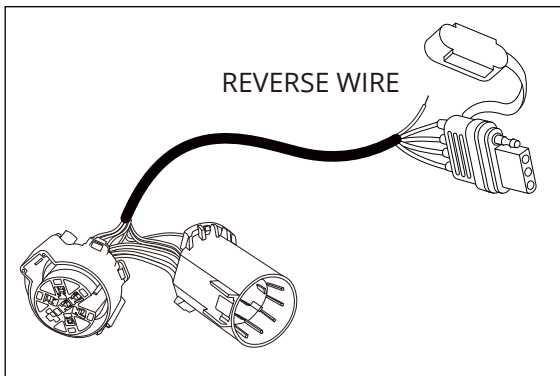

OPT7 Easy Connect USCAR 7 Pin to 4 Pin Harness with Reverse Wire

*Sold separately. Please visit www.opt-7.com for purchasing options.

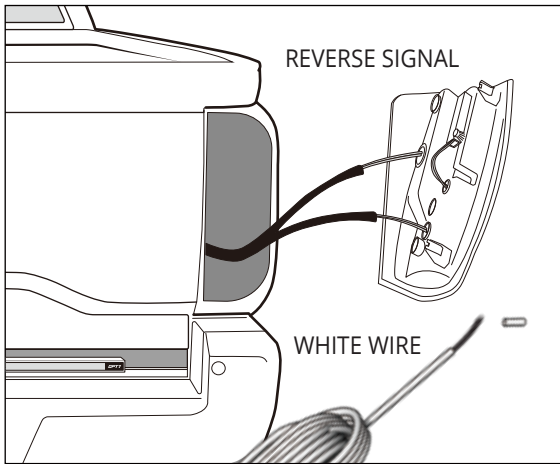

STEP 7 WHERE TO CONNECT THE REVERSE SIGNAL ?

If you are not using the OPT7 Easy Connect USCAR 7 Pin to 4 Pin Harness with Reverse Wire, here is another option to connect the Redline Light Bar Reverse Function. Remove the OEM tail lights to locate the OEM reverse wire, using the provided scotch-loks, tap into the connector.

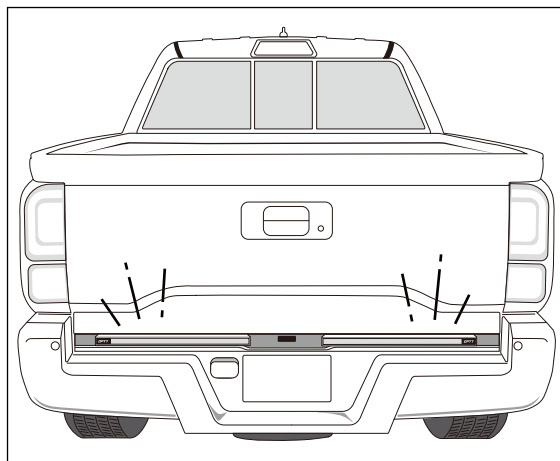

STEP 8

Re-test the functionality of the Redline Parlux Tacoma LED Light Bar. Ensure all the functions are working.

OPTIONAL

OPT7 Easy Connect USCAR 7 Pin to 4 Pin Harness with Reverse Wire

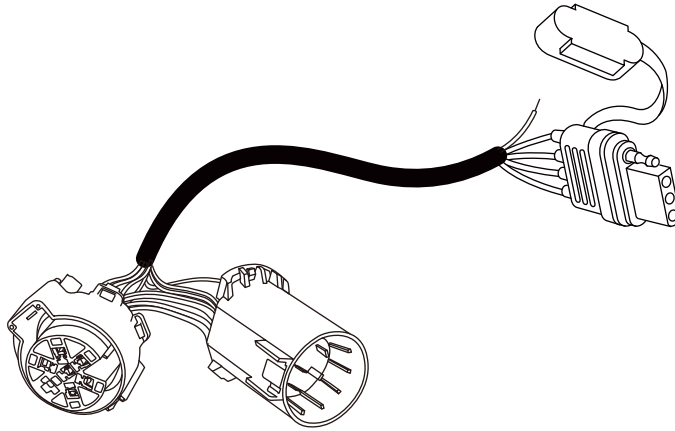

HARD WIRING

If hard-wiring, use image below to identify wire color functions and pair them to appropriately identified wires on vehicle.

TO REDLINE LED BAR

Ground
Running Light
Left Turn & Brake
Right Turn & Brake

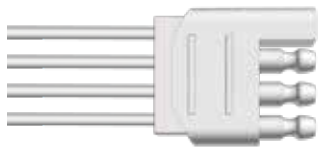

TRAILER HARDWIRE HARNESS

White/Ground
Brown/Running Light
Yellow/Left Turn & Brake
Green/Right Turn & Brake



DISCLAIMER

OPT7 Lighting is not liable for damages, injuries, or death while installing this product. The Installation Guide is intended as assistance to reduce setup time. OPT7 Lighting assumes no responsibility for improper installation. If you are unfamiliar with your vehicle or inexperienced with aftermarket upgrades, please seek professional assistance.

2 YEAR
WARRANTY